

**MICRO  
DYNAMICS**  
*Precision Performance*

**VERTICAL MACHINING CENTER**  
Compact, Durable, Powerful,  
Strong and Accurate



MD202404S.A.E

**MICRO  
DYNAMICS**  
*Precision Performance*

sales@microdynamicsusa.com  
www.microdynamicsusa.com  
www.microdynamicsfa.com



**MEGA  
TERA** SERIES

# VERTICAL MACHINING CENTER

# MEGA TERA SERIES



<b>SPINDLE SPEED</b>	15,000 rpm	18,000 rpm (opt.)	20,000 rpm (opt.)
<b>SPINDLE POWER<sup>(*)</sup></b>	41 HP	41 HP	47 HP
<b>RAPID TRAVERSE</b>	2,047 ipm		
<b>TOOL TO TOOL</b>	1.2 sec		
<b>LOOK AHEAD</b>	2,700 block		

(\*) Peak based on 25% Duty Cycle.

Micro Dynamics Vertical Machining Center Line opens a new era in multi-purpose and versatile machining centers. Compact, durable, powerful, strong and accurate, the **MEGA/TERA Series** starts a revolution in the market: the smallest C-frame machines provide powerful and precise results for manufacturers of dies and molds, aerospace, automotive, semi-conductor, job shops and general machine sectors.

The **MEGA/TERA Series** has been designed with the latest in technology being utilized throughout the machine with productivity in mind. From its EtherNet/IP architecture for easy automation and integration into systems and cells, to its Motion Control for fast and smooth operations used in all industries, the **MEGA/TERA Series** has quickly become one of the industries leading machine tool lines of Vertical Machining Centers.

### POWERFUL

integrated Micro Dynamics® Built-in Spindle.

### THERMAL COMPENSATION

DYPEC® - Dynamic Predictive Error Compensation.

### COMPACT

design with small footprint.

### COLLISION DETECTION

machine stops if a collision is detected in all axis.

### FAST

Mitsubishi CNC M830VW.

### MICRO MILL®

G-code Generator

### STRONG

FC300 Meehanite® casting.

### RIGID TAP

up to 6,000 rpm.

### RELIABLE

highest quality mechanical and electrical components.

### PC BASED HMI

allows user friendly functions.

### INTEGRATED AUTOMATION

EtherNet/IP networked I/O.

### 15" TOUCHSCREEN

ergonomically friendly.

# BUILT-IN SPINDLE

All Micro Dynamics spindles are built with all shelf standard bearings which can be replaced without removing the rotor. This makes all machines simple and fast to maintain. Rebuild costs are very low due to the availability of the parts and the short service time.

- Powerful integrated 40 taper dual contact spindle.
- Maintenance free 15,000 rpm ~18,000 rpm spindle requires no added oil or grease.
- ATE<sup>®</sup> motor integrated with hybrid ceramic angular contact bearings.
- Micro Dynamics drawbar has been rigorously tested to sustain more than 2 million cycles.
- For all applications, from heavy duty to high speed machining.
- Highest productivity under any conditions and complexities.
- CTS (Coolant Through Spindle) designed to sustain up to 100 bar (1,500 psi).<sup>(\*)</sup>

## 15,000 rpm

(40 Taper Dual Contact)



## 18,000 rpm (opt.)

(40 Taper Dual Contact)

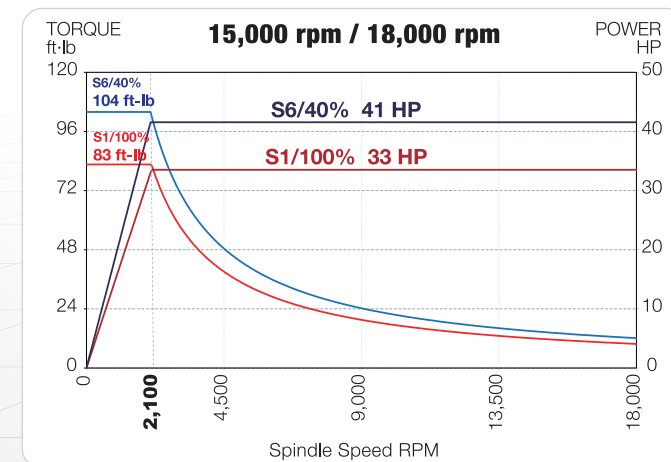
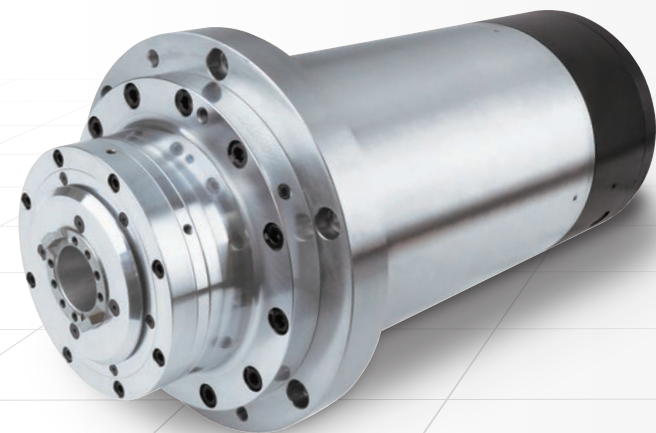

**41 HP** Power

**1.5 sec** Acc. 0 – 12K

**104 ft-lb** Torque

**1.8 sec** Dec. 12K – 0

<sup>(\*)</sup> CTS preparation is standard equipment. CTS system is optional.

## 20,000 rpm (opt.)

(40 Taper Dual Contact)

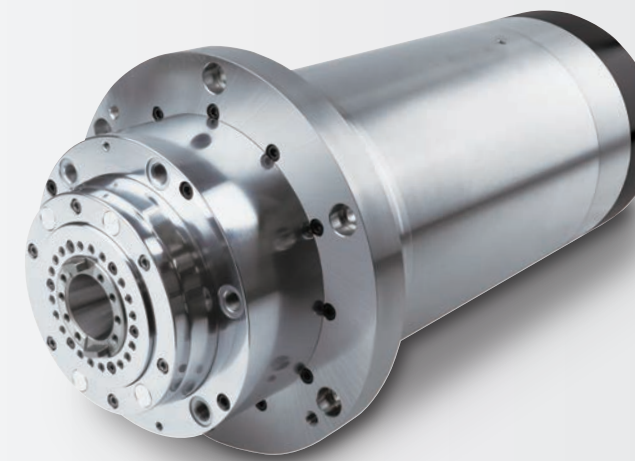

Micro Dynamics optional 20,000 rpm spindle, available on all models, delivers 47 HP of power and 88 ft-lb of torque. This allows for fine finishes while still achieving high material removal rates in a wide range of material types.

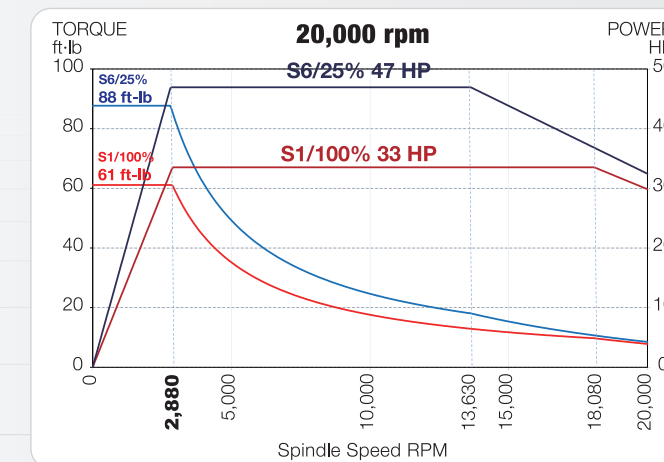

**47 HP** Power

**1.5 sec** Acc. 0 – 12K

**88 ft-lb** Torque

**1.8 sec** Dec. 12K – 0

The **MEGA/TERA Series** has been refined through years of research and development of new technologies that greatly enhance the machines for the rigors of the Mold and Die industry.

- Advanced Motion Control technology that benefits the production of Mold and Die components.
- Highest Quality components to ensure fast and smooth cutting strategies.
- 4G SSS (G05P20000) Motion Control processing speed of up to 540,000 blocks per minute.
- DYPEC<sup>®</sup> - Thermal Compensation. Real time thermal growth compensation, monitoring every few milliseconds, with 0.1 microns compensations to ensure accuracies during long cycle times.

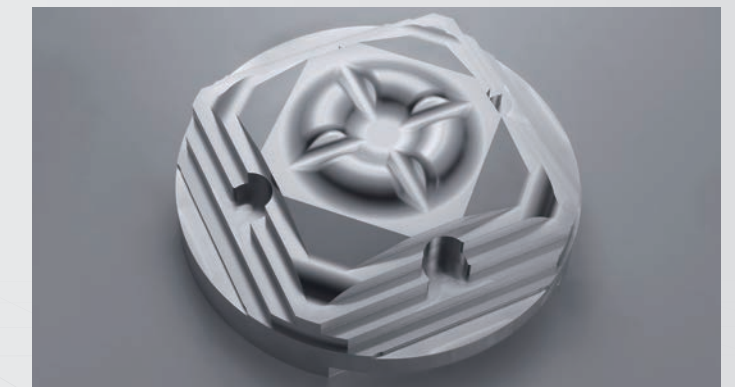

# AUTOMATIC TOOL CHANGER

The **MEGA/TERA Series** is equipped with a high-speed double arm tool changer with a 40-tool magazine<sup>(\*)</sup>. The magazine is integrated on the machine with an isolated structure, eliminating vibrations to the column, thus improving accuracy and finishes. The multi speed double arm allows the operator to adjust the speed of the tool changes for oversized, heavy tools and probes, to ensure accuracy and reliability. The ATC recovery function in HMI is a standard feature that assists the operator in recovering the position of the arm and the tool.

<sup>(\*)</sup> MEGA 30V standard is 30-tool magazine.

## ATC SPEED:

**1.2 sec** Tool to Tool

**2.5 sec** Chip to Chip

Factory Conditions

**ISOLATED STRUCTURE**

## FULL COVER MAGAZINE

The tool magazine is protected from the machining environment reducing chips and coolant from entering the magazine area.

ATC REAR OPERATION PANEL<sup>(\*)</sup> and door allow access for loading, unloading and inspection of tools while the machine is in operation. Tools can be called up either by tool number or by pocket number. During manual operation the machine will continue the cycle without interruption until ATC door is closed and the key is switched to automatic.

<sup>(\*)</sup> Except MEGA 30V.

# CHIP MANAGEMENT SYSTEM

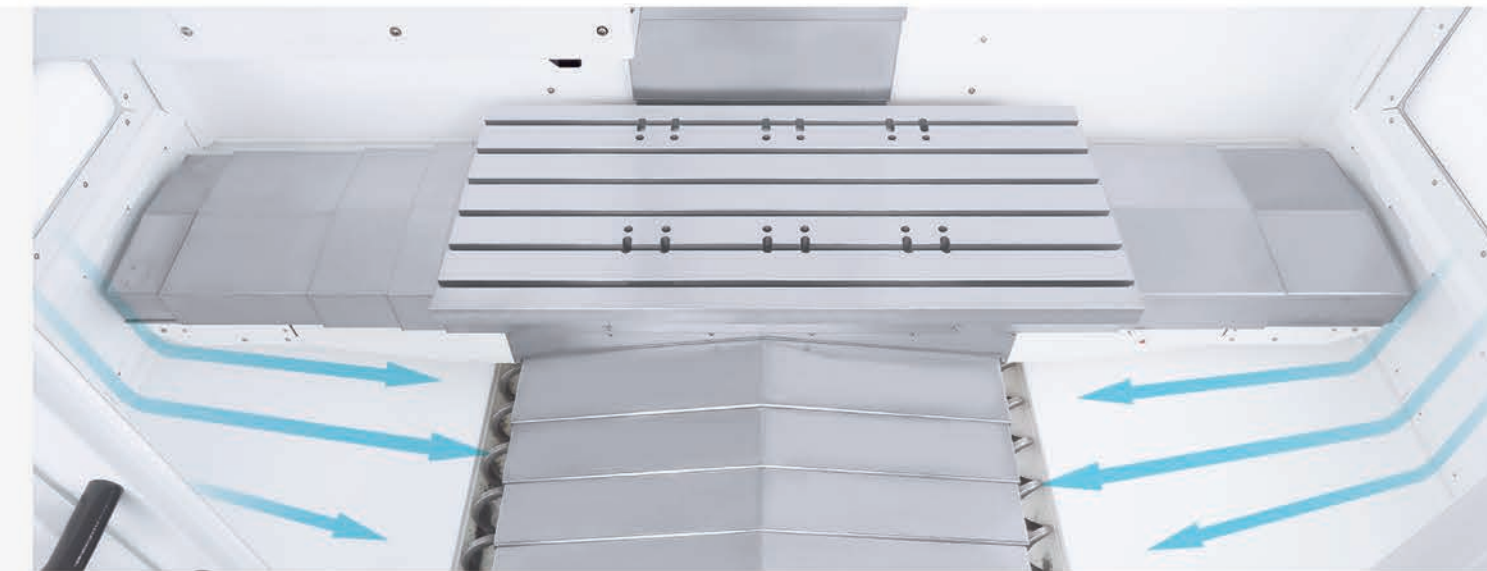

The chip management system includes base wash, dual augers and chip conveyor, virtually eliminating chip build-up. Coolant falls along the inside perimeter flushing chips down to the dual augers which evacuate chips to the front conveyor. All mounting hardware is bolted from the outside leaving a clean surface for chip evacuation.

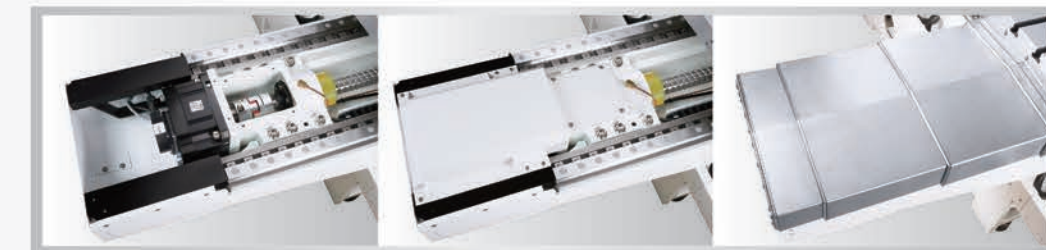

Triple protection on linear guides and ball screws: bottom cover, top cover and telescopic cover.

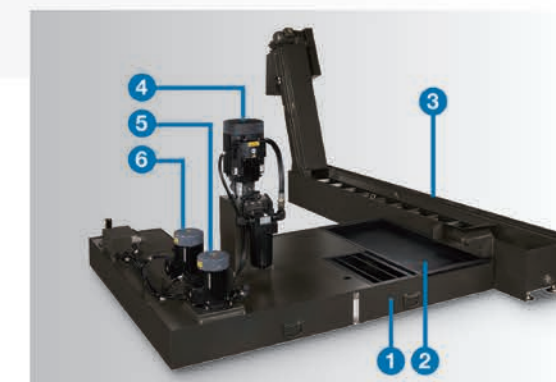

## MODULAR COOLANT/CHIP SYSTEM

- 1. Filter Chip Basket
- 2. Filter Chip Pan
- 3. Chip Conveyor
- 4. CTS Pump Option
- 5. Base Wash Pump
- 6. Coolant Pump



## REVERSIBLE CONVEYOR

standard in all MEGA/TERA Series. Rear chip conveyor available under request.

# ERGONOMICS

**MEGA/TERA Series** is ergonomically designed for operator and maintenance convenience. The large wide front door can be opened with one hand. There are three LED lights, two in the sides and one over the work area.

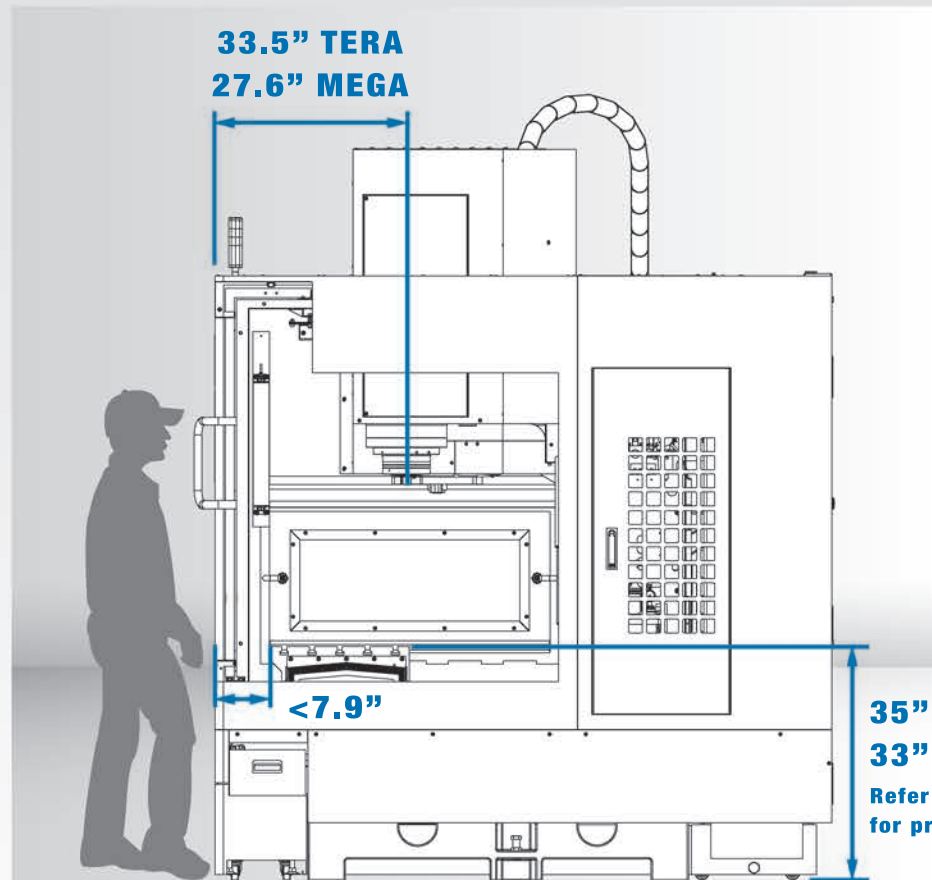

Headstock service door to facilitate access is standard on all models.

**35\"/>**

The distance from the door to the table is less than 7.9\"/>

Two axes motion operator panel offers flat, tilting and swivel control.



# DYPEC<sup>®</sup> THERMAL COMPENSATION

**DYPEC<sup>®</sup>, Dynamic Predictive Error Compensation,** corrects position error caused by thermal changes which improves accuracy and part finishes (resolution 0.1 μm).

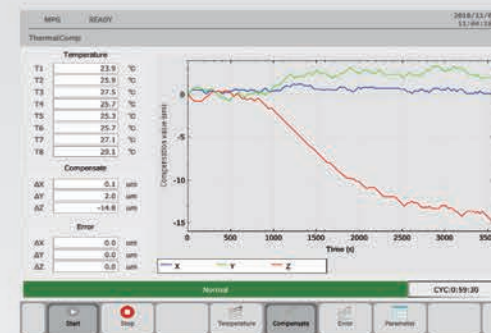

DYPEC<sup>®</sup> software chart in HMI



DYPEC<sup>®</sup> mirror milling with ball end mill

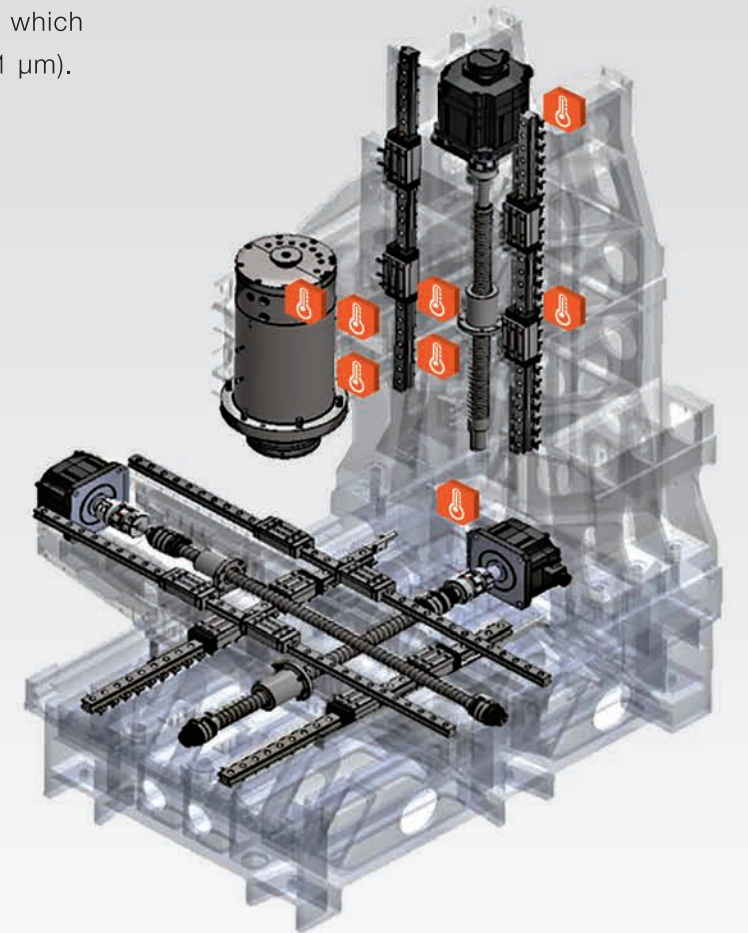

**THERMAL SENSOR**

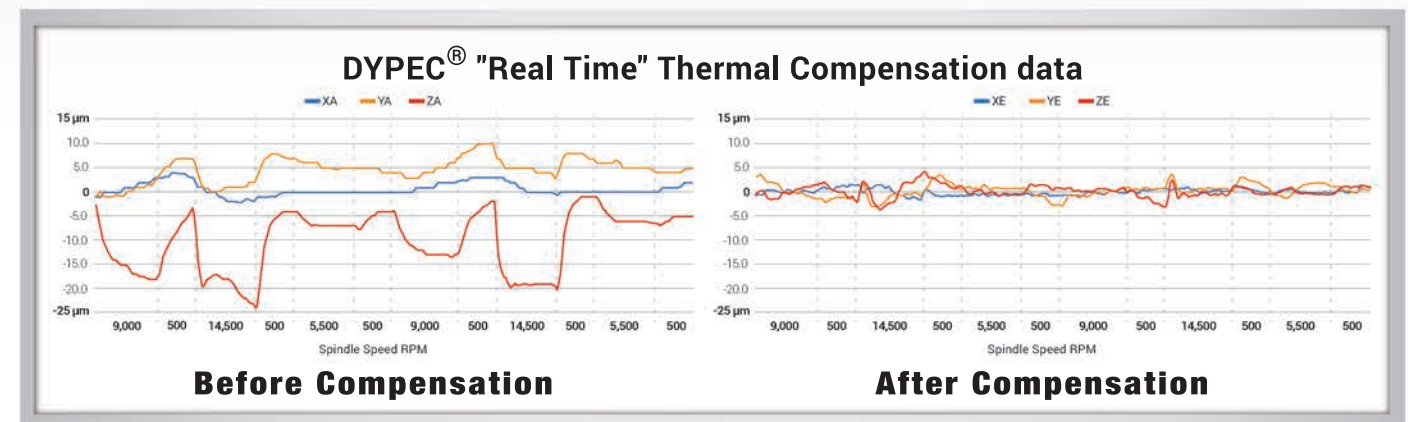

X/Y/Z axis static in micron error before and after DYPEC<sup>®</sup> compensation (48 hours test).

# MICRO DYNAMICS® HMI

The Windows® embedded HMI CNC gives the user the ability to create or add apps to make it flexible to operate and automate the machine. Operator can load, run or edit any program from any device: internal HMI memory, PC hard drive or external USB device.



## COLLISION DETECTION

Machine stops if a collision is detected in all axis.

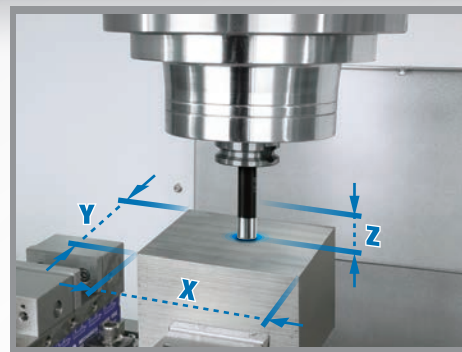

## AUTO PART SETUP

X, Y, Z work offset can be achieved with a hard probe.



## PART SETUP

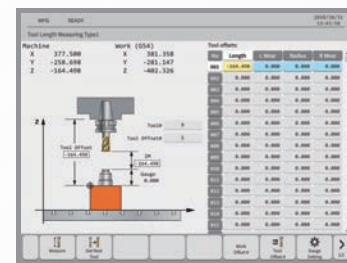

## TOOL SETUP

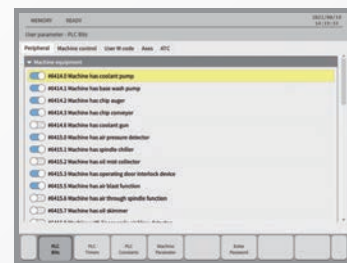

## PARAMETER SETUP

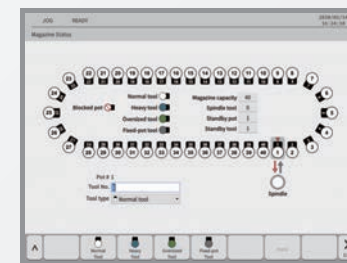

## MAGAZINE MONITOR



**ATC RECOVERY** function allows the operator to recover the tool changer.



**APC RECOVERY** function allows the operator to recover the pallet changer.

## Micro Dynamics® features:

- Mitsubishi CNC M830VW series.
- 15" Touchscreen display.
- 5,400 Block Look Ahead.
- 60 GB Data Server.
- 1,000 Programs in editing memory.
- 999 Sets in tool compensation.
- DXF import.
- 54 Sets work offsets.
- 400 Sets tool life management.
- 8,000 Sets macro variable.
- 64 Bit microprocessor.
- 2,048 KB Program memory.
- Main and subprograms can be edited and run as one file.
- Programs can be run from the front side USB or the hard drive.
- 3D circular interpolation.
- G-Code guidance.
- Helical interpolation.
- NURBS interpolation. (\*)
- Programmable in-position check.
- Scaling.
- Simple programming (NAVI mill conversational programming).
- 4G SSS Control (Super Smooth Surface).
- Tolerance control.
- Spiral/conical interpolation.
- Tool Center Point Control.
- 3D tool radius compensation.
- Workpiece position offset for rotary axis.
- Inverse time feed.
- Polar coordinate command.
- Upgradable to 5 axes simultaneous control. (\*)

(\* ) Optional for U.S. market only.

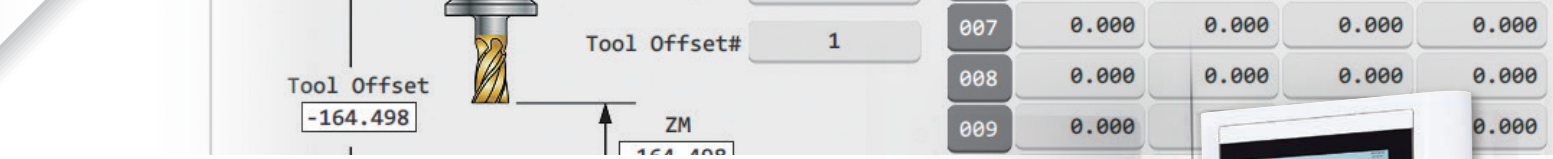

The **MEGA/TERA Series** features Mitsubishi CNC M830VW Control which is well suited to high-speed, high-accuracy machining and multi-axis, multi-part system control. Mitsubishi's tool path graphics verification makes it easier for end users to check G-Code program before machining.

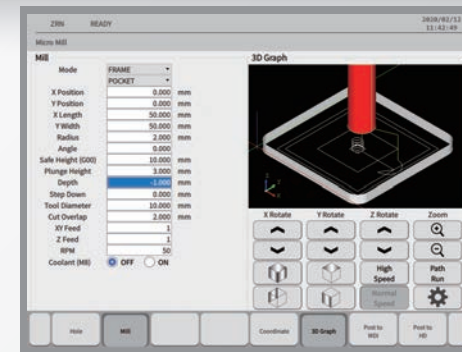

**MICRO MILL®** is an interface that allows any operator to easily perform milling and drilling operations while creating G-Code and post to MDI or main memory.

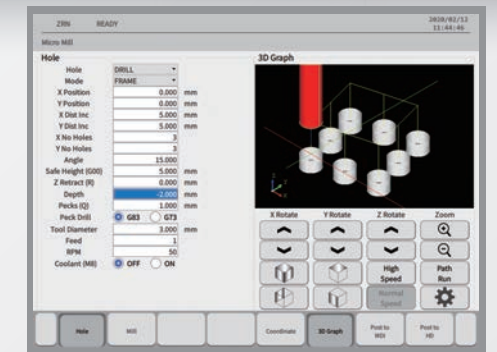

# MEGA 20VAPC

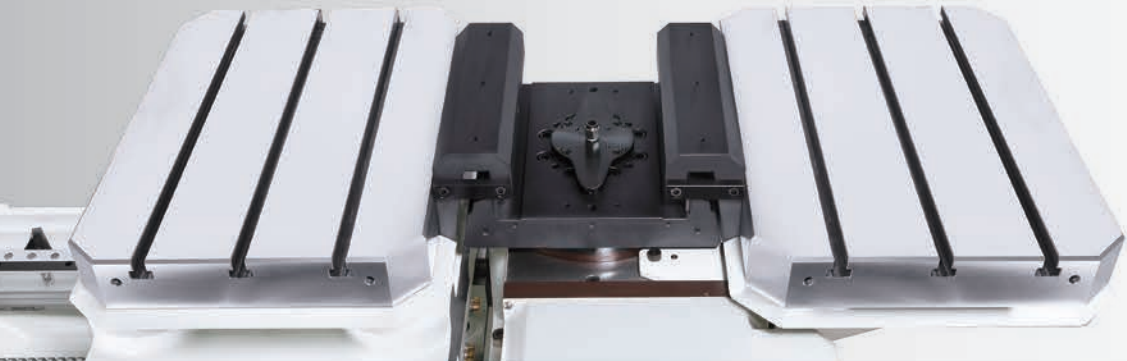

**SERVO DRIVEN  
PALLET CHANGER**

Dual pallet changer MEGA 20VAPC is designed for high production. The servo driven pallet changer switches tables in 8.5 sec. With the APC recovery function in the HMI the operator can easily perform maintenance of the pallet changer.

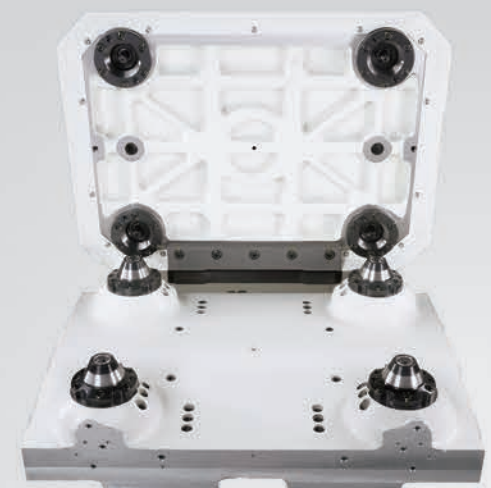

Pressurized cones



# MEGA 30VT / TERA 50VT

The MEGA 30VT and TERA 50VT are Micro Dynamics's five-axis trunnion (4+1) table machines with hydraulic brakes. The design allows the user to load three vises or can be used as a 20" x 11.8" work table with a 8.7" diameter face plate<sup>(\*)</sup> in MEGA 30VT and 28.3" x 15.8" work table with a 12.6" diameter face plate<sup>(\*\*)</sup> in TERA 50VT.

For automation the through hole of the rotary table allows for the plumbing of hydraulics, pneumatics or other devices. A true five-axis simultaneous version is available as an option.

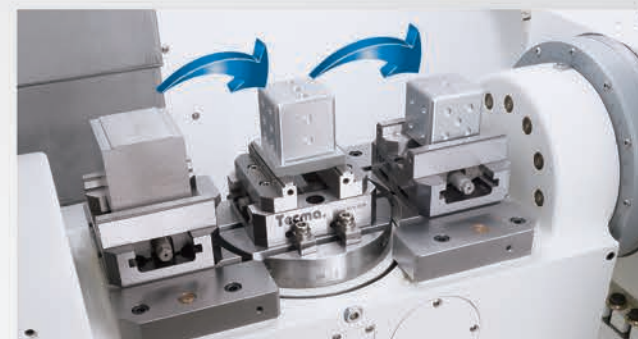

**MACHINE 6 SIDES IN ONE LOAD**

- Left vise: cut dove tail.
- Central vise: 5-side machining.
- Right vise: finish dove tail.



Titling axis and Rotary axis motion ranges.

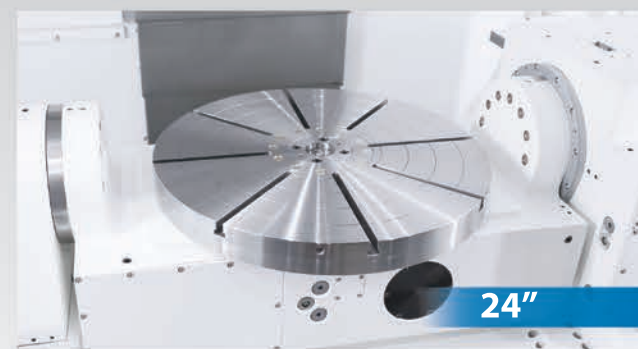

- (\*) **MEGA 30VT:** 12" and 14" diameter face table. (opt.)
- (\*\*) **TERA 50VT:** 20" and 24" diameter face table. (opt.)

# MACHINING CAPACITY

## FACE MILL



**MATERIAL REMOVAL:**  
**46.7 cu in/min**

**SPINDLE LOAD:**  
**87%**

- Tool: **2.5" Face Mill**
- Material: 1050 Steel
- Cut: 2.00" x 0.24"
- Feedrate: 100 ipm
- Spindle Speed: 2,173 rpm

## END MILL



**MATERIAL REMOVAL:**  
**22.5 cu in/min**

**SPINDLE LOAD:**  
**47%**

- Tool: **1.25" End Mill**
- Material: 1050 Steel
- Cut: 1.26" x 0.20"
- Feedrate: 91 ipm
- Spindle Speed: 3,800 rpm

## DRILL



**MATERIAL REMOVAL:**  
**51 cu in/min**

**SPINDLE LOAD:**  
**90%**

- Tool: **1.75" Drill**
- Material: 1050 Steel
- Diameter Cut: 1.77"
- Cutting Depth: 1.38"
- Feedrate: 21 ipm
- Spindle Speed: 2,100 rpm

## TAP



**SPINDLE LOAD:**  
**46%**

- Tool: **1.25" x 7" Tap**
- Material: 1050 Steel
- Feedrate: 15 ipm
- Spindle Speed: 128 rpm

Factory Conditions

## FACTORY TEST

Micro Dynamics standard factory tests for all models includes the circle, diamond, square cutting test, as well as milling, drilling, tapping and the heavy milling test based on below parameters:

- Tool: 2" End Mill
- Material: 1050 Steel
- Cutting Width: 0.9"
- Cutting Depth: 0.3"
- Feedrate: 28 ipm
- Spindle Speed: 1,100 rpm
- Load: 40%



# ACCURACY

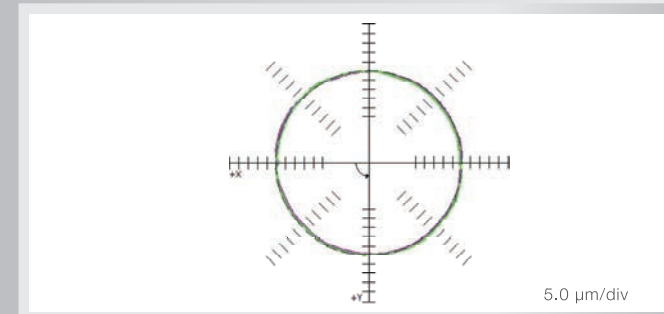
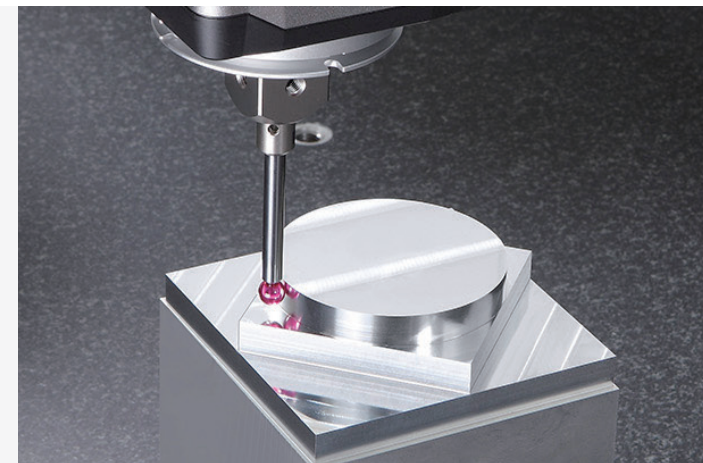

E.g. XY Double Ball Bar Test Results under 5 microns.

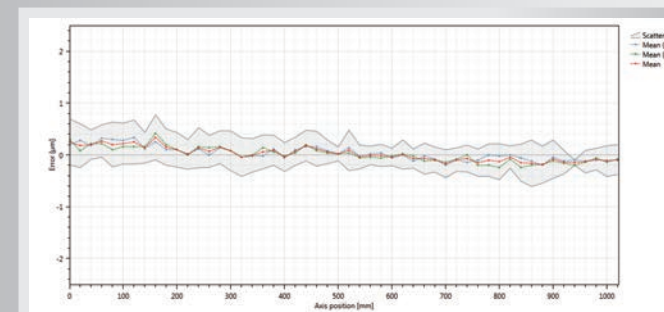

E.g. X Axis Laser Compensation under 5 microns.

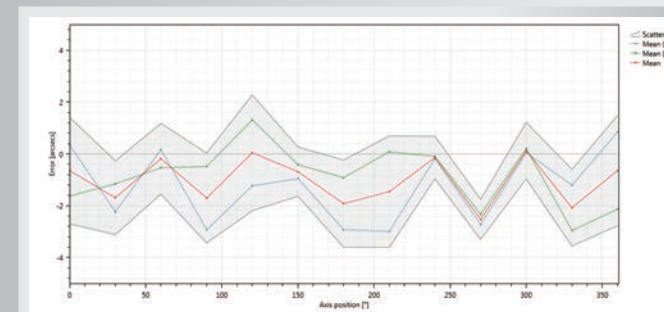

E.g. 5th Axis Laser Compensation under 10 arcsecs.

Micro Dynamics circle, diamond, square cutting test is done on all machines prior to shipment at 59 ipm with a maximum tolerance under 5 microns linear.

- XY, XZ and YZ Double Ball Bar Test Results at 59 ipm under 5 microns.
- X, Y and Z Axis Laser Compensation under 5 microns.
- 4th and 5th Axis Laser Compensation under ±10 arcsecs.

16% Squareness	6.3 μm/m
16% Backlash X	← -0.3 μm → 0.9 μm
13% Reversal spikes X	← -0.8 μm → -0.4 μm
12% Cyclic error Y	↑ 0.8 μm ↓ 0.7 μm
10% Lateral play X	← 0.8 μm → 0.4 μm
Circularity	2.7 μm

Factory Conditions

Linear X - Analysis features	VDI 3441
Name	Value (μm)
Maximum reversal (U max)	0.2
Maximum scatter (Ps max)	0.8
Positional uncertainty (P)	1.4
Positional deviation (Pa)	0.5
Mean reversal	0.1
Mean scatter (Ps mean)	0.5

(Without scales)

Factory Conditions

Angular C - Analysis features	VDI 3441
Name	Value (arcsecs)
Maximum reversal (U max)	3.1
Maximum scatter (Ps max)	2.1
Positional uncertainty (P)	5.9
Positional deviation (Pa)	2.7
Mean reversal	1.5
Mean scatter (Ps mean)	1.5

(Without scales)

Factory Conditions



# MEGA 30V



## MACHINE DIMENSIONS

Unit: mm (inch)

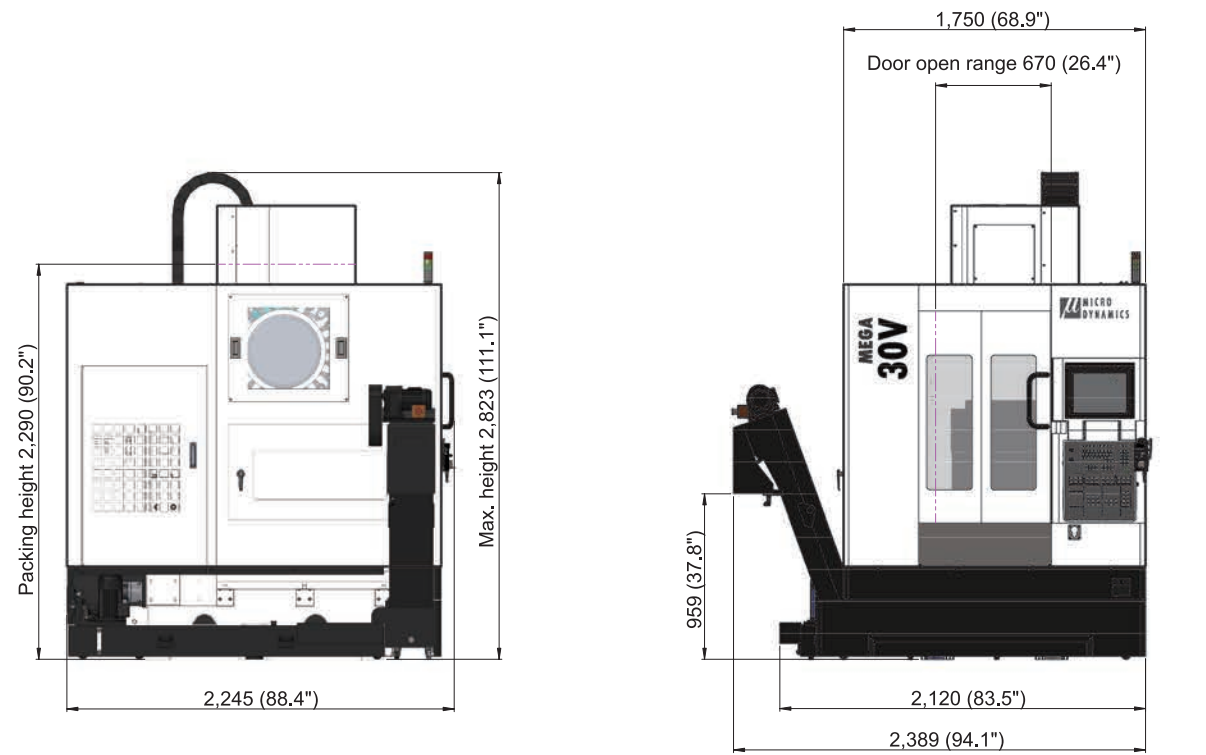

# MEGA 40V



## MACHINE DIMENSIONS

Unit: mm (inch)

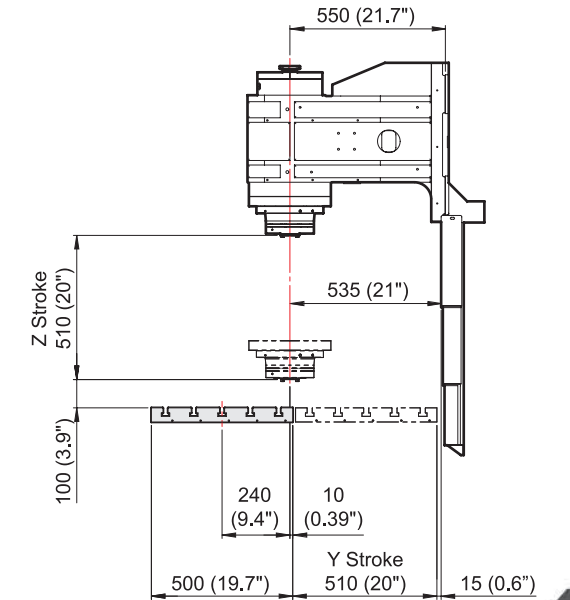
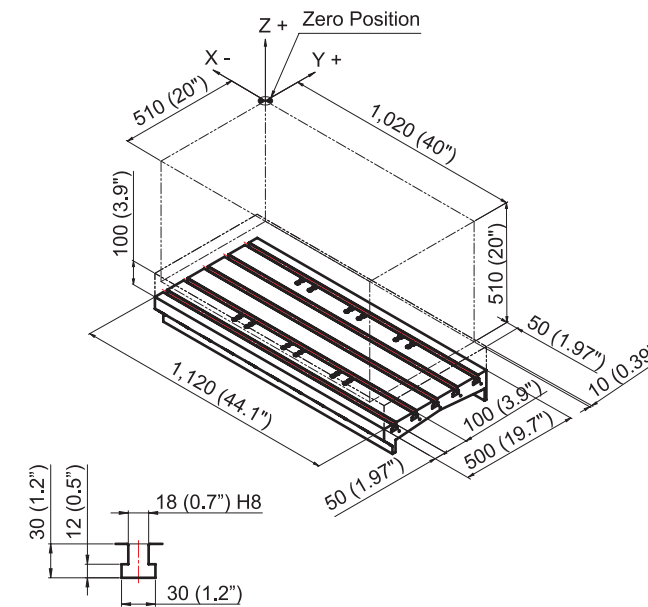
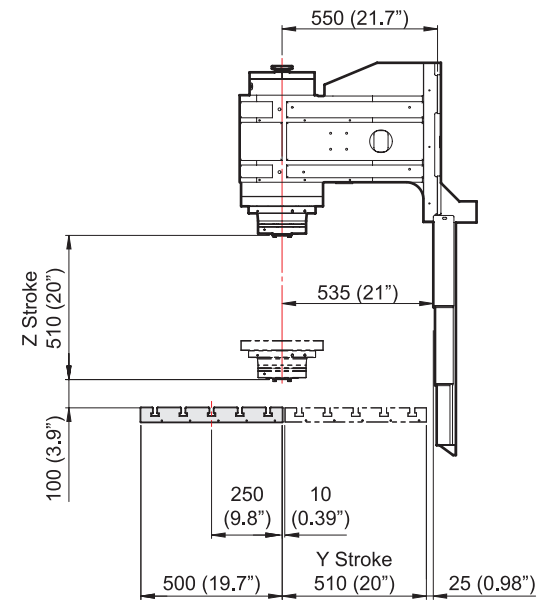
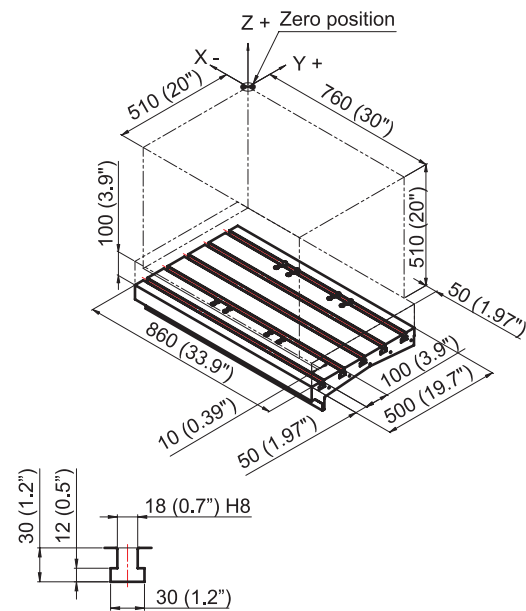
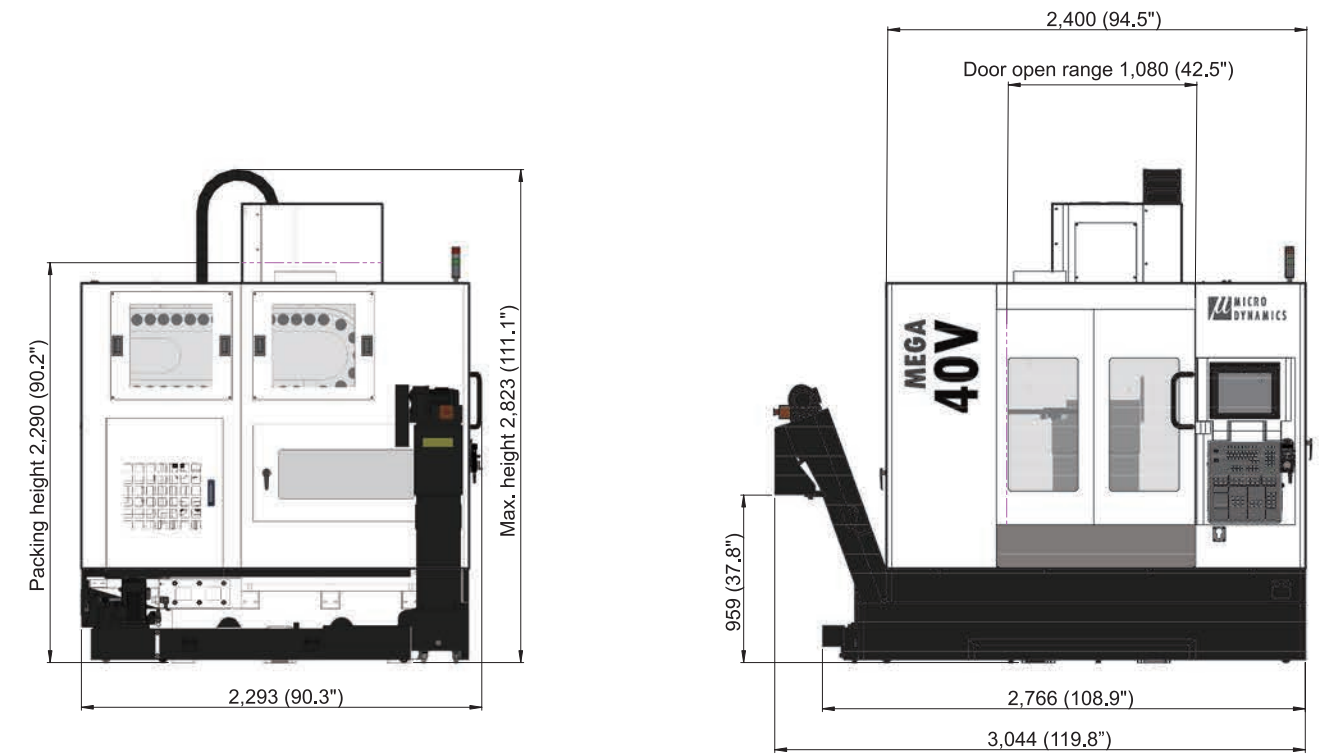

# MEGA 20VAPC



## MACHINE DIMENSIONS

Unit: mm (inch)

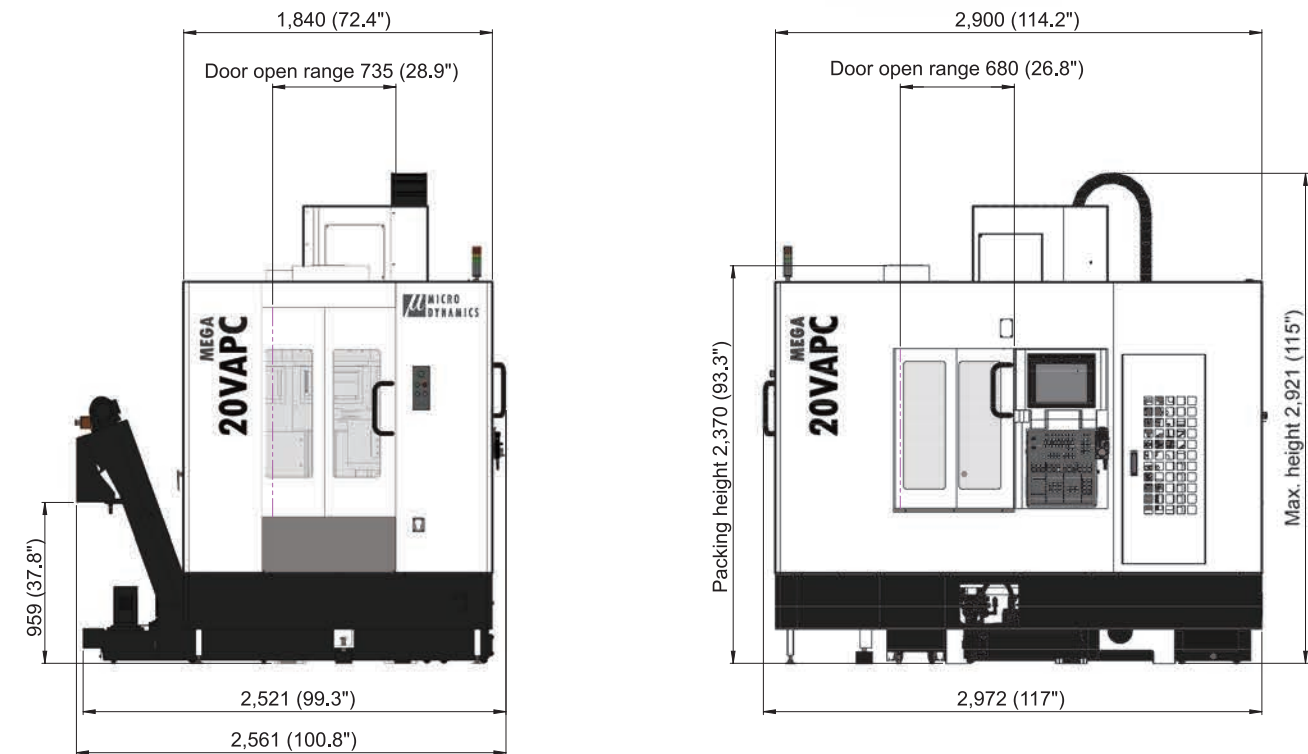

# MEGA 30VT



## MACHINE DIMENSIONS

Unit: mm (inch)

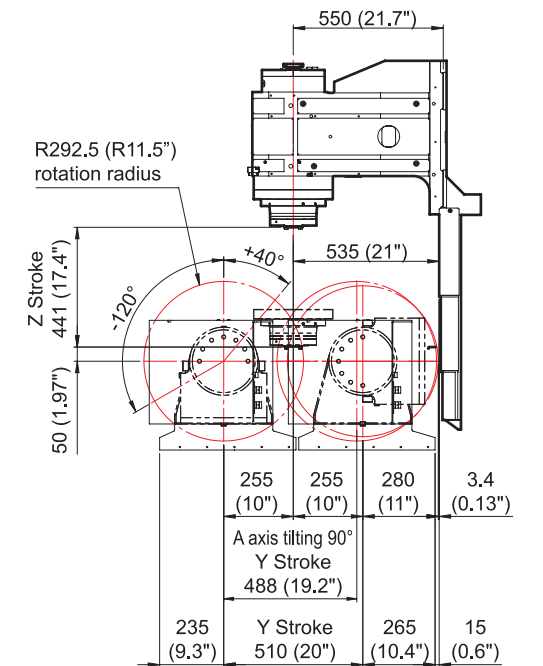
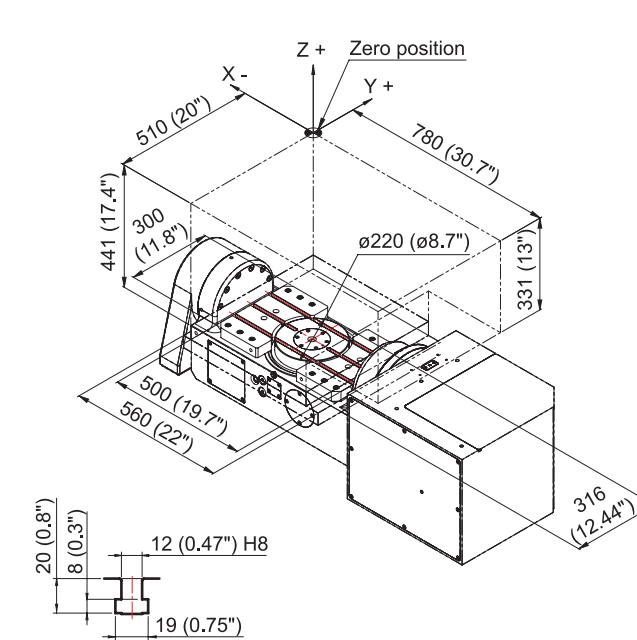
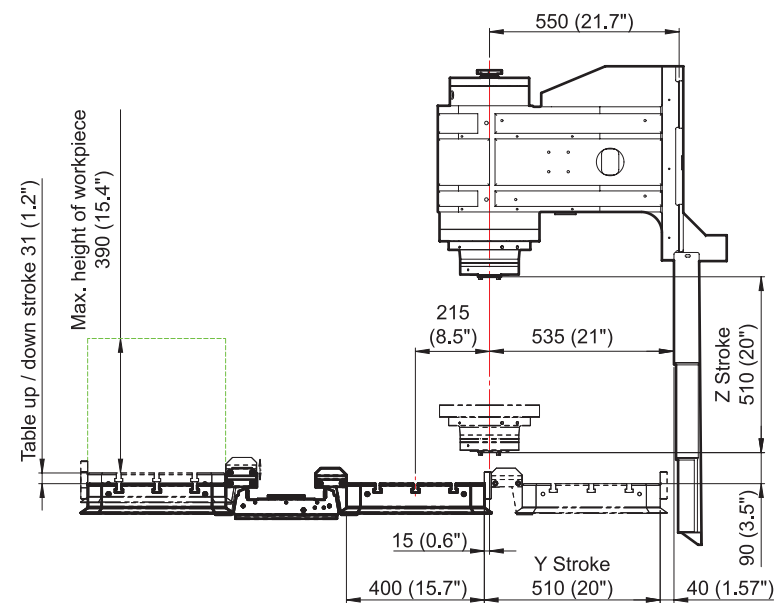
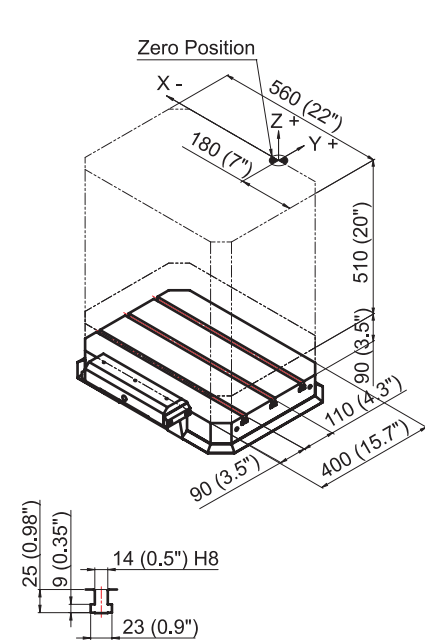
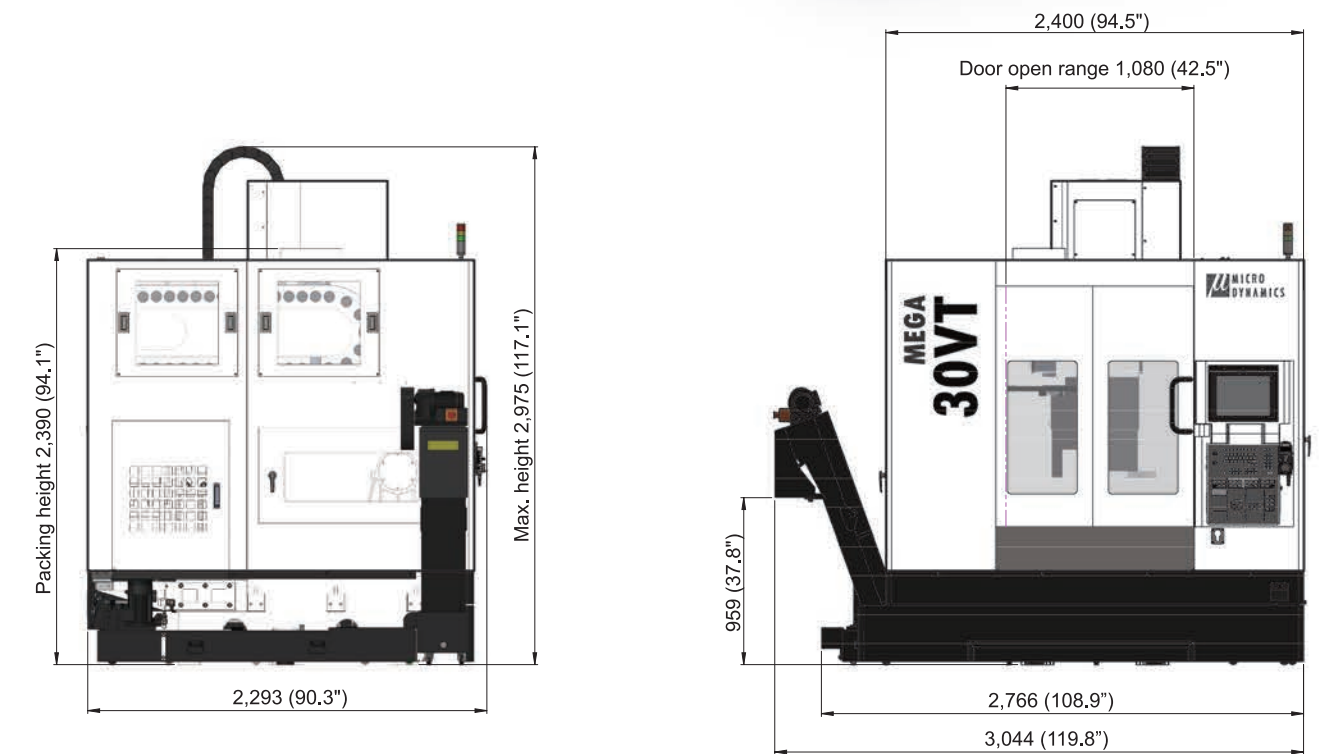

# TERA 40V



## MACHINE DIMENSIONS

Unit: mm (inch)

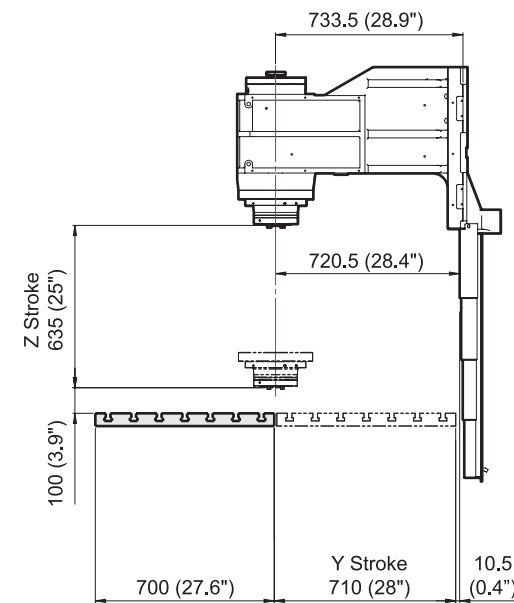
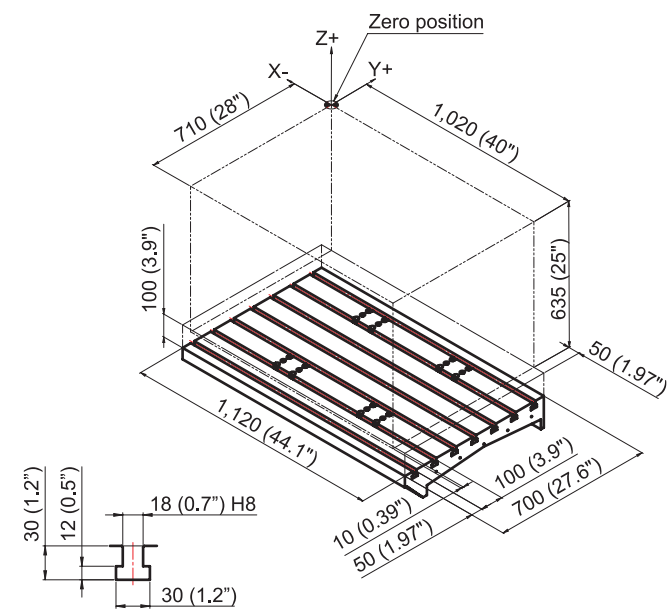
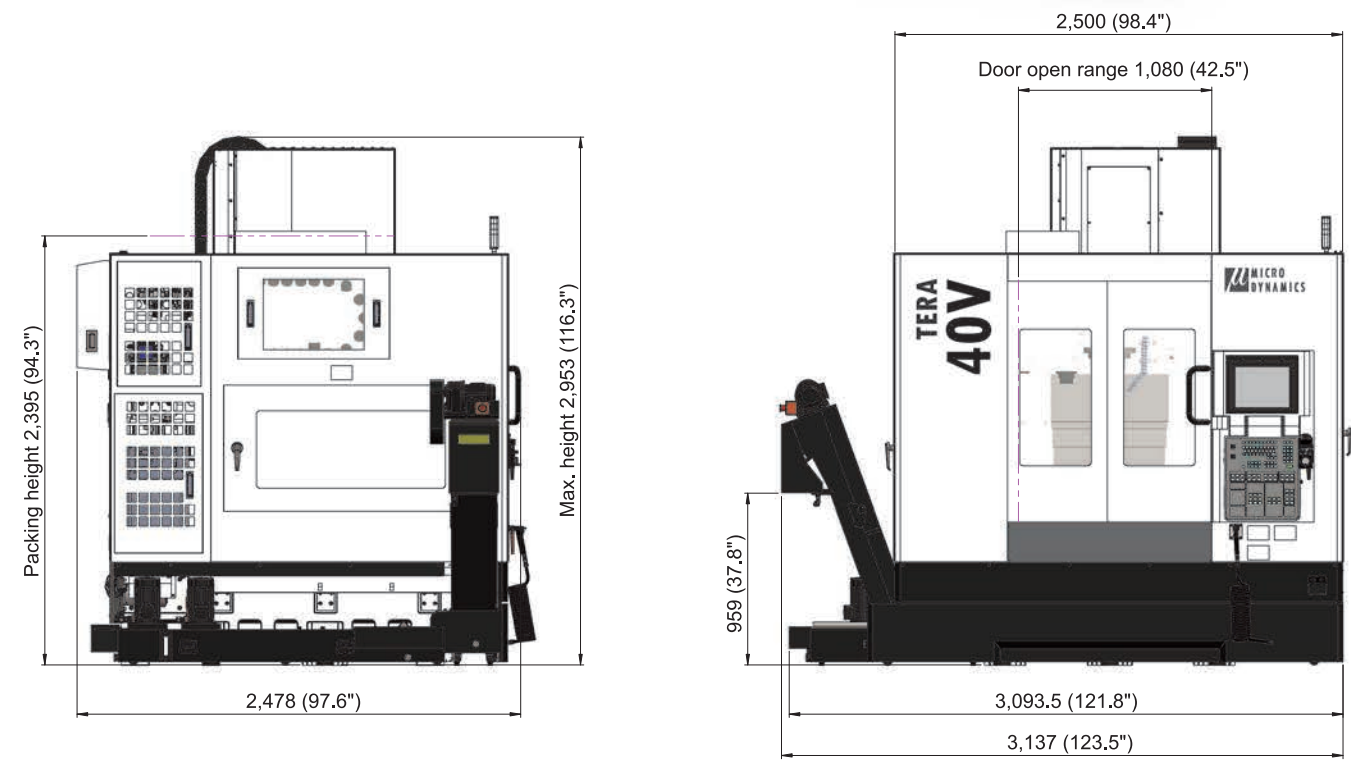

# TERA 50V



## MACHINE DIMENSIONS

Unit: mm (inch)

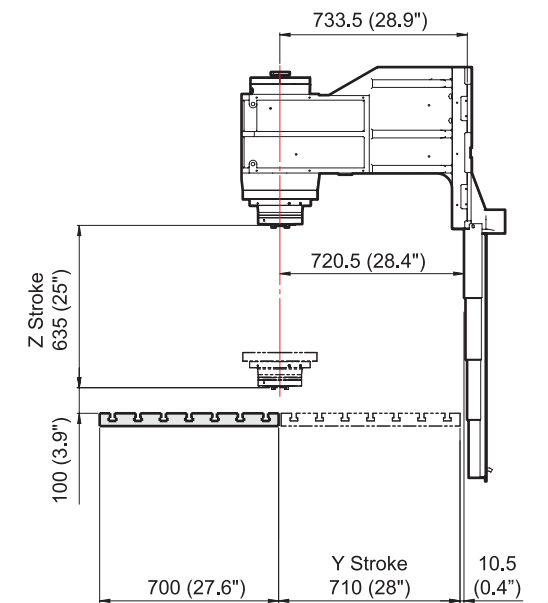
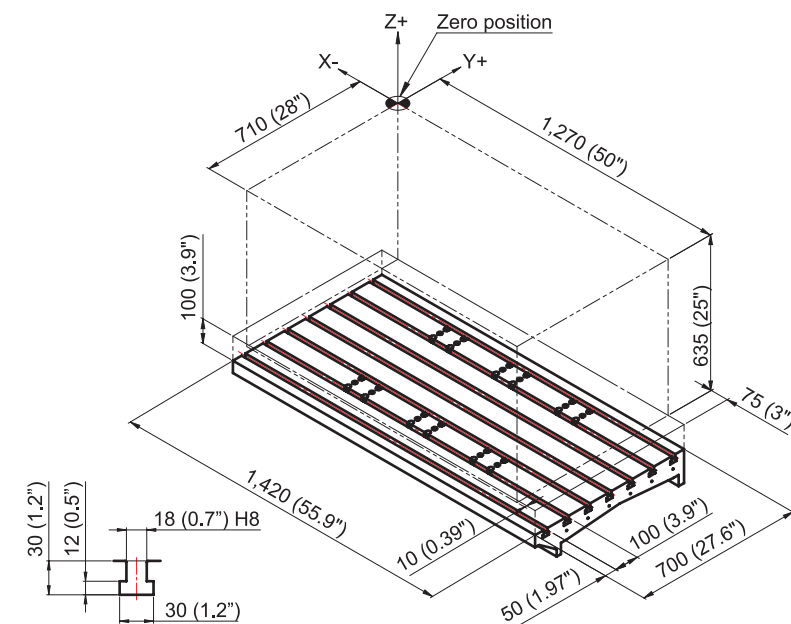
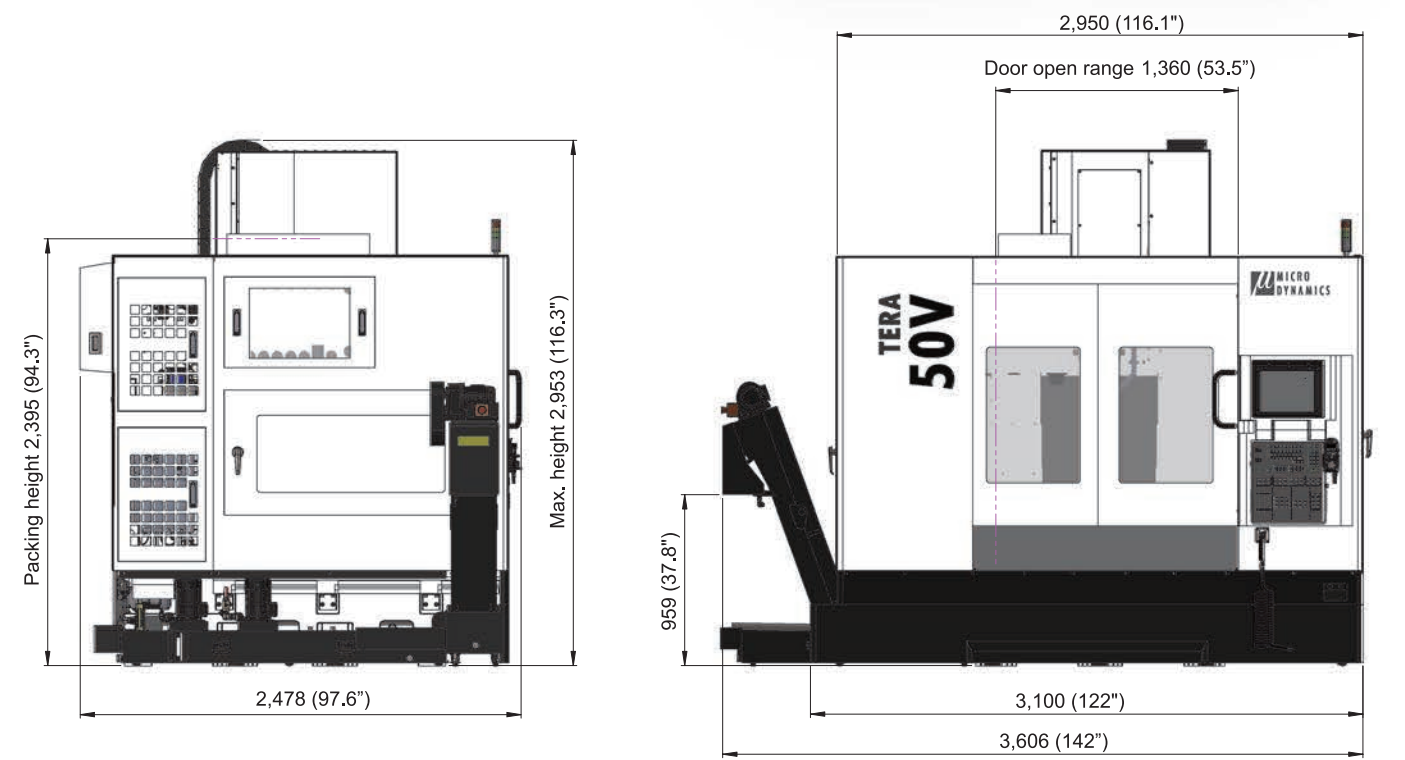

# TERA 60V



## MACHINE DIMENSIONS

Unit: mm (inch)

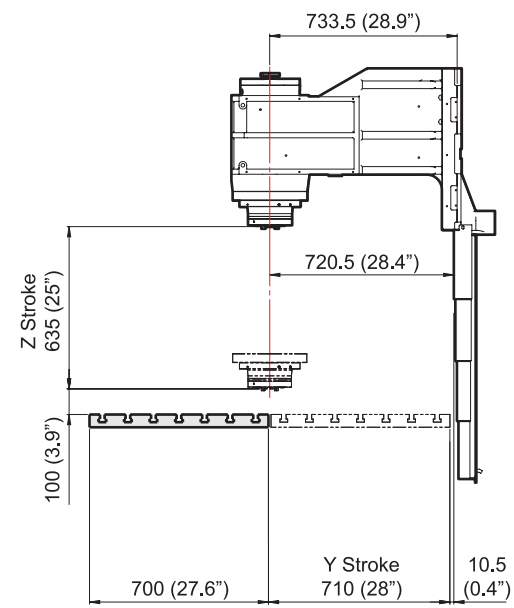
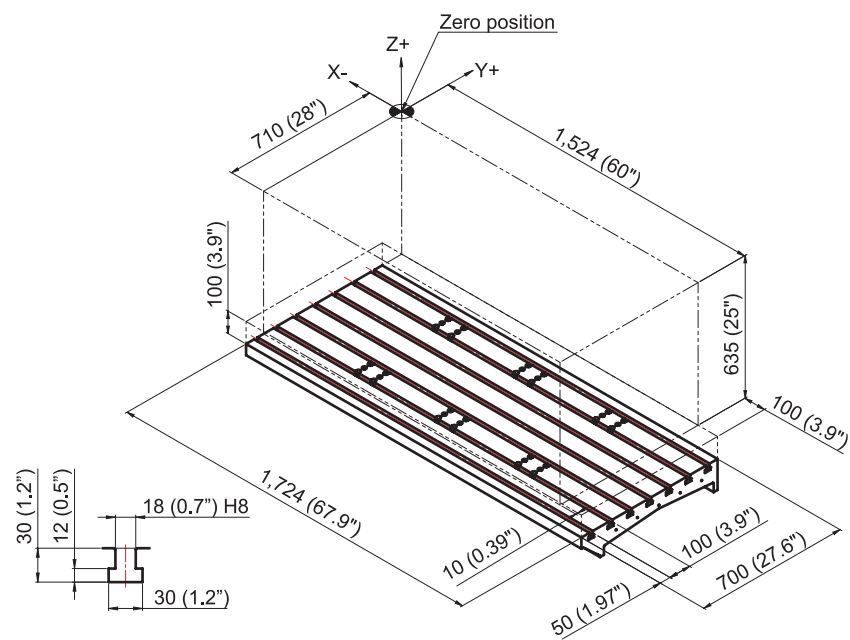
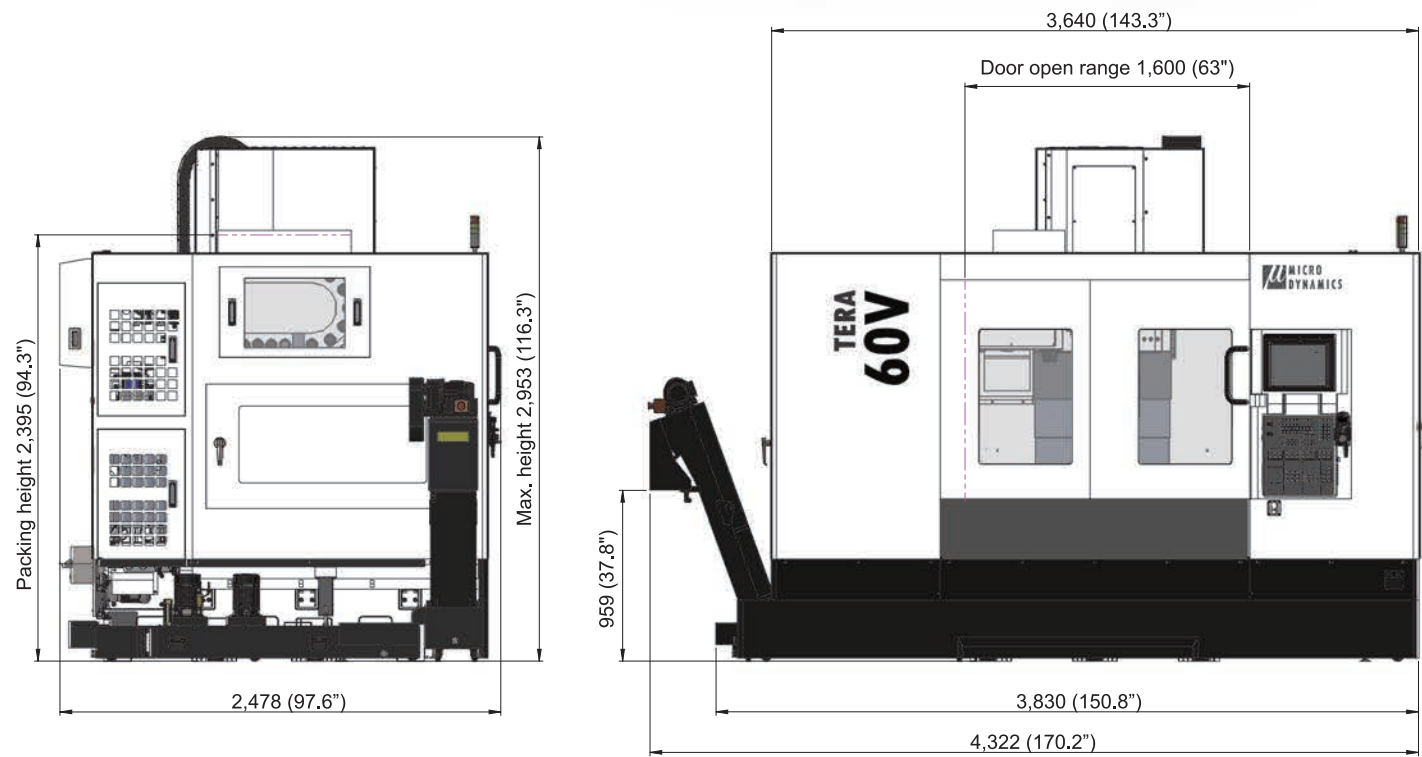

# TERA 50VT



## MACHINE DIMENSIONS

Unit: mm (inch)

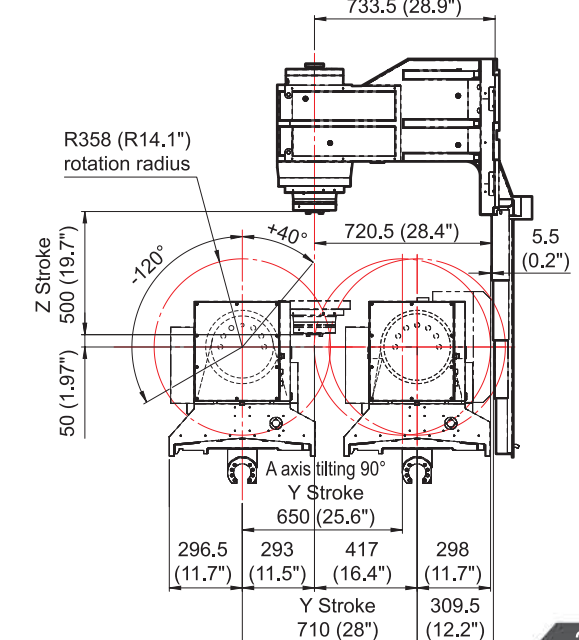
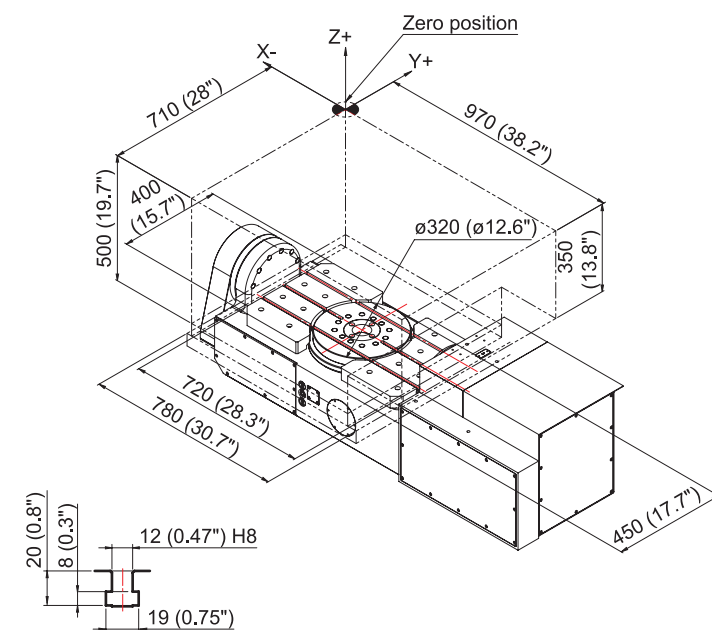
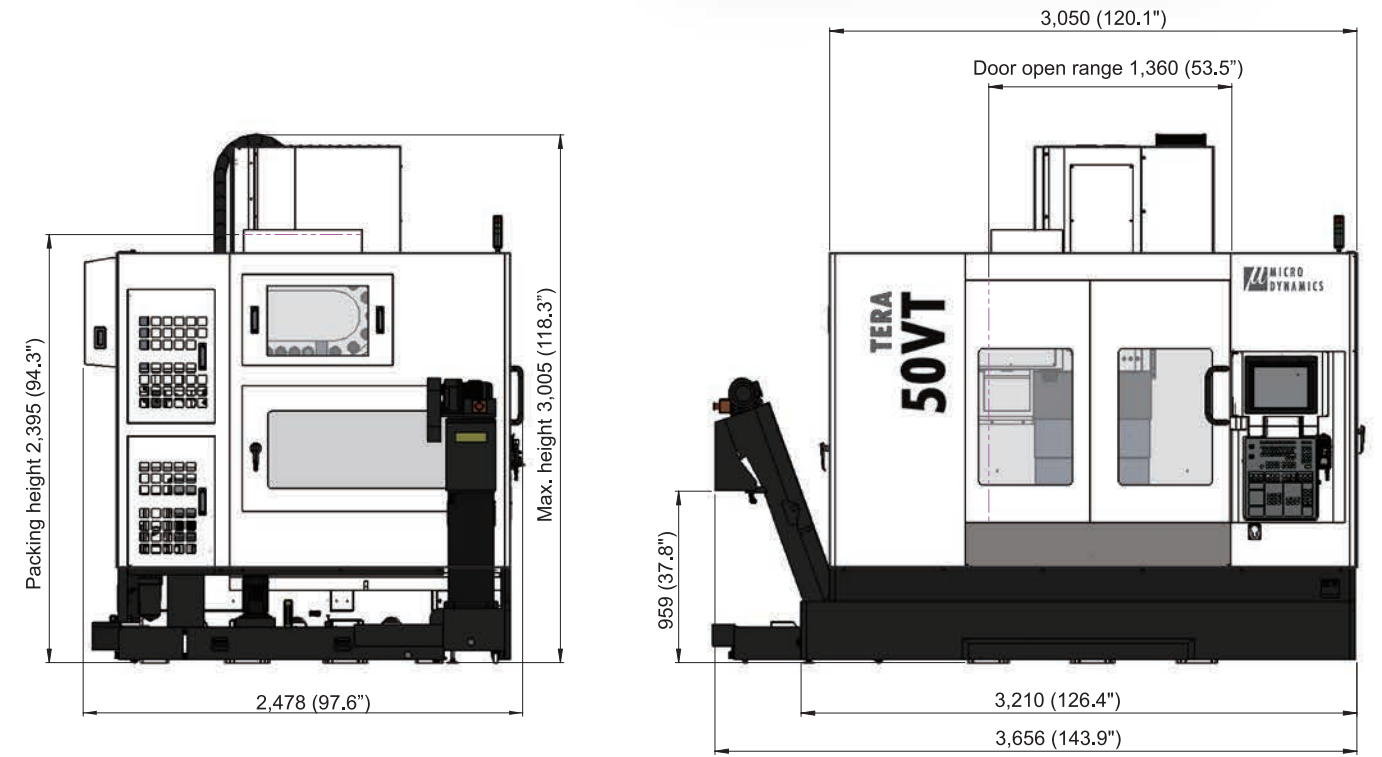

# EQUIPMENT

● Standard ○ Optional

SERIES / MODELS	MEGA				TERA				
	30V	40V	20VAPC	30VT	40V	50V	60V	50VT	
<b>Spindle</b>	15,000 rpm Built-in Spindle	●	●	●	●	●	●	●	
	18,000 rpm Built-in Spindle	○	○	○	○	○	○	○	
	20,000 rpm Built-in Spindle	○	○	○	○	○	○	○	
<b>Accuracy &amp; Scales</b>	DYPEC® Thermal Compensation	●	●	●	●	●	●	●	
	X/Y/Z Axis Linear Scale	○	○	○	○	○	○	○	
	A/C Axis Rotary Scale	-	-	-	○	-	-	○	
<b>Control &amp; HMI</b>	15" Touchscreen Display	●	●	●	●	●	●	●	
	Micro Dynamics® HMI	●	●	●	●	●	●	●	
	Tool Measurement / Workpiece Measurement	○	○	○	○	○	○	○	
	8 M-Codes (M20 ~ M27)	●	●	●	●	●	●	●	
	Additional 8 M-Codes (M130 ~ M137)	○	○	○	○	○	○	○	
	Automatic Power Off	●	●	●	●	●	●	●	
<b>Tool Magazine</b>	Tool Magazine Capacity - 30 (*)	●	-	-	-	-	-	-	
	Tool Magazine Capacity - 40 (*)	-	●	●	●	●	●	●	
	Servo Tool Magazine (**)	○	○	○	○	○	○	○	
	ATC Auto Door (**)	○	○	○	○	○	○	○	
	ATC Magazine Panel	-	●	●	●	●	●	●	
	Tool Magazine LED	●	●	●	●	●	●	●	
<b>4th / 5th Axis</b>	4th Axis Pre-wiring	○	○	○	○	○	○	○	
	Metal Coolant Ring	○	○	○	○	○	○	○	
	Spinning Window	○	○	○	○	○	○	○	
	20-Bar (290 psi) / 40-Bar (580 psi) / 70-Bar (1,000 psi) CTS	○	○	○	○	○	○	○	
<b>Coolant &amp; Chip Management</b>	CTS Preparation (without Rotary Union)	●	●	●	●	●	●	●	
	Coolant Gun & Air Gun	●	●	●	●	●	●	●	
	Scraper Type Chip Conveyor	●	●	●	●	●	●	●	
	Chain Type Chip Conveyor	○	○	○	○	○	○	○	
	Drum Type Chip Conveyor	○	○	○	○	○	○	○	
	Rear Type Chip Conveyor (**)	○	○	○	○	○	○	○	
	Twin Chip Augers	●	●	●	●	●	●	●	
	Disc Type Oil Skimmer	○	○	○	○	○	○	○	
	Oil Mist Collector	○	○	○	○	○	○	○	
	<b>Column Riser</b>	MEGA series 100 / 150 / 250 mm (3.9" / 5.9" / 9.8") (**)	○	○	○	○	-	-	-
		TERA series 120 mm (4.7") (***)	-	-	-	○	○	○	○
<b>Face Plate</b>	300 / 350 mm (12" / 14") Diameter Face Table	-	-	-	○	-	-	-	
	500 / 630 mm (20" / 24") Diameter Face Table	-	-	-	-	-	-	○	
<b>Safety &amp; Power</b>	CE-Conformity Package	○	○	○	○	○	○	○	
	Transformer	○	○	○	○	○	○	○	
<b>Automation</b>	Automatic Door (Pneumatic / Servo)	○	○	○	○	○	○	○	
	Full Chip Enclosure	●	●	●	●	●	●	●	
<b>Others</b>	Safety Door	●	●	●	●	●	●	●	
	Manuals / Tool Kit / Foundation Kit	●	●	●	●	●	●	●	

(\*) Factory order (\*\*) MEGA 20VAPC standard is 100 mm (3.9"), MEGA 30VT standard is 150 mm (5.9"). (\*\*\*) TERA 50VT standard is 120 mm (4.7").

## RETENSION KNOB

### BT 40

#### Pull Stud JIS6339

Unit: mm (inch)

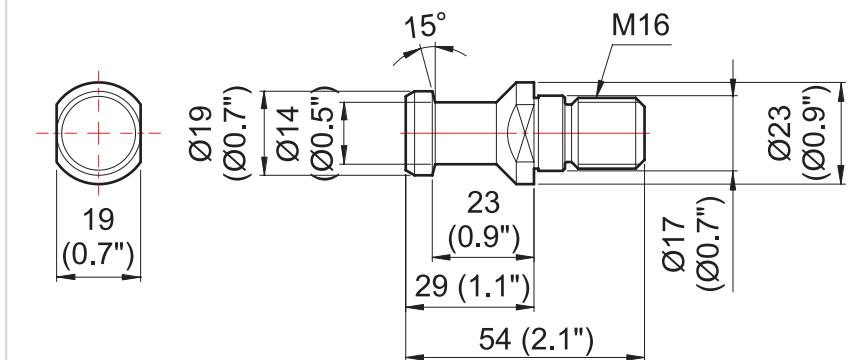

### CAT 40

#### Pull Stud CAT DIN40

Unit: mm (inch)

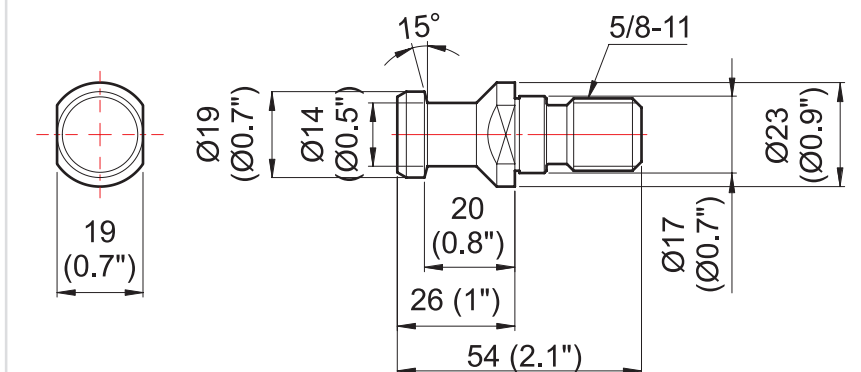

# SPECIFICATIONS

ITEM	UNIT	MEGA 30V	MEGA 40V	MEGA 20VAPC	MEGA 30VT	TERA 40V	TERA 50V	TERA 60V	TERA 50VT	
<b>TRAVEL</b>	X Axis	inch	30"	40"	24"	30"	40"	50"	38"	
	Y Axis	inch	20"	20"	20"	20"	28"	28"	28" / 25.4" (90°)	
	Z Axis	inch	20"	20"	20"	17.4"	25"	25"	19.7"	
	A Axis (Tilting Axis)	deg		N/A		40° ~ -120°		N/A	40° ~ -120°	
	C Axis (Rotary Axis)	deg		N/A		360°		N/A	360°	
	Spindle Nose to Table Surface	inch	3.9" ~ 24"	3.9" ~ 24"	3.5" ~ 23.6"	1.97" ~ 19.3"	3.9" ~ 29"	3.9" ~ 29"	3.9" ~ 29"	1.97" ~ 21.7"
	Spindle Center to Column Front	inch	21.7"	21.7"	21.7"	21.7"	28.9"	28.9"	28.9"	28.9"
<b>TABLE</b>	Table Size	inch	33.9" x 19.7"	44.1" x 19.7"	22" x 15.7"	ø8.7" (19.7" x 11.8")	44.1" x 27.6"	55.9" x 27.6"	67.9" x 27.6"	ø12.6" (28.3" x 15.7")
	Min. Table Index Unit	deg		N/A		0.001°		N/A		0.001°
	Max. Table Load	lb	1,764	2,205	441 x 2	331 (0°~45°) / 187 (45°~90°)	3,307	3,307	4,409	551 (0°~45°) / 331 (45°~90°)
	Table Height (from the Ground)	inch	33.1"	33.1"	37.4"	43.6"	35.4"	35.4"	35.4"	47.4"
<b>SPINDLE</b>	Spindle Taper		40 Taper Dual Contact							
	I.D. of Spindle Bearing	inch	ø2.75"							
	Spindle Speed	rpm	50 ~ 15,000 (optional 18,000 & 20,000)							
	Max. Power	hp	41							
	Max. Cutting Torque	ft-lbf	104							
	Max. Speed for Rigid Tapping	rpm	6,000							
<b>FEEDRATE</b>	Rapid Feedrate - X Axis	ipm	2,047	2,047	2,047	1,889	2,047	2,047	2,047	1,889
	Rapid Feedrate - Y Axis	ipm	2,047	2,047	2,047	1,889	2,047	2,047	2,047	1,889
	Rapid Feedrate - Z Axis	ipm	1,889	1,889	1,889	1,889	1,889	1,889	1,889	1,889
	Rapid Feedrate - A (Tilting) Axis	rpm		N/A		25		N/A		33
	Rapid Feedrate - C (Rotary) Axis	rpm		N/A		33		N/A		66
	Cutting Feedrate	ipm	0 ~ 787							
<b>ATC</b>	Magazine Capacity		30					40		
	Tool Selection		Bi-Direction / Random							
	Tool Shank Type		BT40 / CAT40							
	Pull Stud Type		JIS6339 / CAT DIN40							
	Max. Tool Diameter x Length	inch	ø3" x 9.1"	ø3" x 11.8"	ø3" x 9.4"	ø3" x 11.8"	ø3" x 10.2"	ø3" x 11.8"	ø3" x 11.8"	ø3" x 11.8"
	Without Adjacent Tool	inch	ø6"							
	Max. Tool Weight	lb	15.4							
<b>PERIPHERAL</b>	Power Consumption (220V/3PH)	KVA		30					40	
	Pneumatic Supply	L/min (ANR)	300 (0.6MPa)							
	Cutting Coolant Pump Motor	hp	1.5							
	Base Wash Pump Motor	hp	1.5							
	CTS Pump Motor (Opt.)	hp	4							
	Coolant Tank Capacity	gal	66	79	79	79	79	106	106	106
	Foot Print Size (W x D)	inch	94.1" x 88.4"	119.8" x 90.3"	100.8" x 117"	119.8" x 90.3"	123.5" x 97.6"	142" x 97.6"	170.2" x 97.6"	143.9" x 97.6"
	Machine Height (H)	inch	111.1"	111.1"	115"	117.1"	116.3"	116.3"	116.3"	118.3"
	Packing Size (W x D x H)	inch	108.3" x 90.6" x 100.4"	129.9" x 90.9" x 100.4"	126" x 86.6" x 100.4"	129.9" x 90.9" x 100.4"	133.9" x 90.9" x 100.4"	161.4" x 90.9" x 100.4"	192.9" x 90.9" x 100.4"	133.9" x 90.6" x 100.4"
	Machine Net Weight	lb	10,780	12,368	14,109	13,999	17,725	18,960	20,216	21,076
	Machine Gross Weight	lb	11,177	12,897	14,793	14,528	18,254	19,599	21,076	21,848
Positioning Accuracy / Full Stroke	inch	0.0002" (VDI 3441)								
Repeatability Accuracy	inch	0.0001" (VDI 3441)								

Note: Specifications subject to change without notice.